

**SKF**



# SKF Shaft Alignment Tool TKSA 20

Instructions for use



## Table of contents

<b>EC Declaration of conformity .....</b>	<b>3</b>
<b>Safety recommendations .....</b>	<b>4</b>
<b>1. Introduction .....</b>	<b>5</b>
1.1 Principle of operation.....	5
1.2 Machine configuration.....	5
1.3 Measuring positions.....	6
<b>2. Shaft alignment tool.....</b>	<b>7</b>
2.1 Technical data.....	10
<b>3. Instructions for use .....</b>	<b>11</b>
3.1 Measurement units .....	11
3.2 Feet on the ground.....	11
3.3 Attachment of measuring units.....	11
3.4 Switch on .....	12
3.5 Aiming the laser lines .....	12
3.6 Machine dimensions.....	15
3.7 Measuring sequence.....	16
3.8 Alignment results.....	17
3.8.1 Measured misalignment.....	17
3.8.2 Vertical alignment .....	17
3.8.3 Horizontal alignment .....	19
3.9 Verify alignment.....	20
3.10 Soft foot.....	21
<b>4. Alignment report.....</b>	<b>22</b>
<b>5. Advanced use .....</b>	<b>24</b>
5.1 Limited rotation .....	24
5.2 Trouble shooting .....	24
5.2.1 The system does not switch on.....	24
5.2.2 No laser lines .....	24
5.2.3 No measurement values.....	24
5.2.4 Fluctuating measurement values .....	24
5.2.5 Incorrect measuring results.....	25
5.2.6 Measurement results cannot be repeated .....	25
<b>6. Maintenance.....</b>	<b>25</b>
6.1 Handle with care.....	25
6.2 Cleanliness.....	25
6.3 Batteries of the display unit.....	25
6.4 Replacement of measuring units or display unit.....	25
6.5 Spare parts and accessories.....	26

## EC Declaration of conformity

We, SKF Maintenance Products, Kelvinbaan 16,  
3439 MT Nieuwegein, declare that

### SKF Shaft Alignment Tool TKSA 20

has been designed and manufactured in accordance with  
EMC DIRECTIVE 2004/108/EC as outlined in the harmonized norm for  
Emission: EN 61000-6-3:2007  
Immunity: EN 61000-6-2:2005, EN 61000-4-2, -3

Directive RoHS, 2002/95/EC

The laser is classified in accordance with the EN 60825-1:2007.  
The laser complies with 21 CFR 1040.10 and 1040.11 except for deviations  
pursuant to Laser Notice No. 50, dated June 24, 2007.

The Netherlands, March 2010



Sébastien David  
Manager Product Development and Quality



### Safety recommendations

- Always turn off the power of the drive machine before you start working.
- Do not expose the equipment to rough handling or heavy impacts.
- Always read and follow the operating instructions.
- The tool uses two laser diodes with an output power below 1 mW. Still, never stare directly into the laser transmitter.
- Calibrate the equipment regularly.
- Never aim the laser line into someone's eyes.
- Opening the housing of the measuring unit may result in hazardous light exposure and voids warranty.
- The equipment should not be used in areas where there is a risk for explosion.
- Do not expose the equipment to high humidity or direct contact with water.
- All repair work should be taken care of by an SKF repair shop.

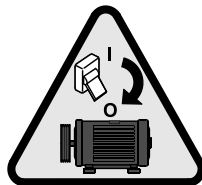

# 1. Introduction

Perfect alignment of machinery shafts is crucial to prevent premature bearing failure, shaft fatigue, sealing problems and vibrations. It further reduces the risk of over-heating and excessive energy consumption. The SKF Shaft Alignment Tool TKSA 20 offers an easy and accurate way of adjusting two units of rotating machinery so that the shafts of the units are in a straight line.

## 1.1 Principle of operation

The TKSA 20 system uses two measuring units both provided with a laser diode and a positioning detector. As the shafts are rotated through 180° any parallel misalignment or angular misalignment causes the two laser lines to deflect from their initial relative position.

The measurements from the two positioning detectors automatically enter the logic circuitry inside the display unit, which calculates the misalignment of the shafts and advises on corrective alignments of the machine feet.

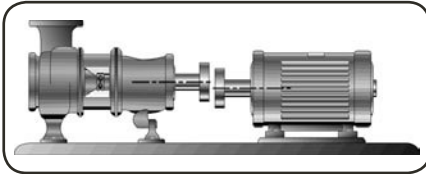

Fig. 1. Parallel misalignment

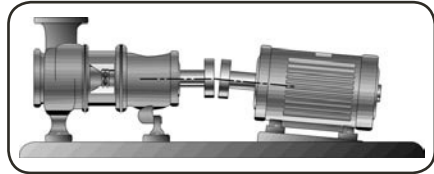

Fig. 2. Angular misalignment

After a straightforward measuring procedure, the tool immediately displays the misalignment of the shafts and the necessary corrective adjustments of the feet of the machine. Since the calculations are done in real time the progress of the alignment can be followed live.

## 1.2 Machine configuration

During the alignment procedure we will refer to the part of the machinery which will be adjusted as the “Movable machine”. The other part we will refer to as the “Stationary machine”.

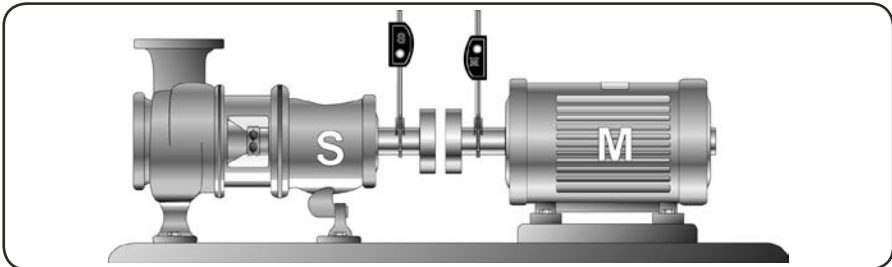

Fig. 3. Stationary and Movable machine

### 1.3 Measuring positions

To define the various measuring positions during the alignment procedure we use the analogy of a clock as viewed from behind the Movable machine. The position with the measuring units in an upright position is defined as 12 o'clock while 90° left or right is defined as 9 and 3 o'clock.

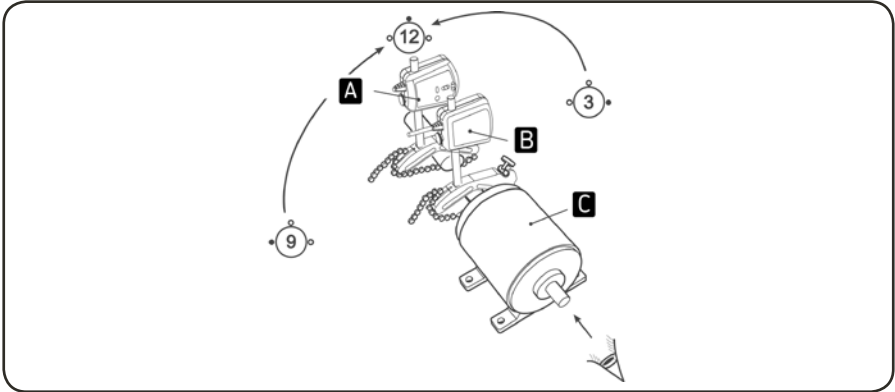

Fig. 4. The analogy of a clock

- A Stationary
- B Movable
- C Movable machine

## 2. Shaft alignment tool

The following components are included with the TKSA 20 tools:

- Display unit
- 2 measuring units with spirit levels
- 2 mechanical shaft fixtures
- 2 locking chains
- Measuring tape
- Quick start guide
- Certificate of calibration
- CD ROM, including:
  - Instructions for use
  - Quick start guide
  - Demonstration video
  - Shaft alignment report
- Batteries
- Carrying case



*Fig. 5. Tool components*

Details of the display unit and the mechanical fixture with measuring unit can be seen on figures 6 and 7.



- 1 Connector for measuring unit on Stationary machine
- 2 Connector for measuring unit on Movable machine
- 3 LCD Display
- 4 ON/OFF button
- 5 Increase (+) button
- 6 Next button
- 7 Decrease (-) button
- 8 Previous button
- 9 Machine dimensions (A,B and C) / Measured values (S and M)
- 10 Rear feet values
- 11 Front feet values
- 12 Indication of parallel coupling value direction
- 13 Indication of angular coupling value direction
- 14 Position (9/12/3 o'clock) of measuring units
- 15 Low battery
- 16 Imperial or metric units

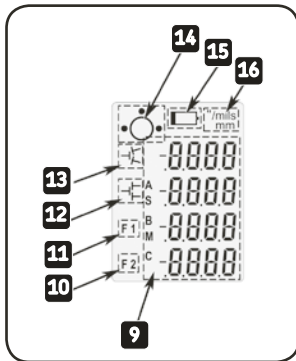

Fig. 6. Display unit



Fig. 7. Mechanical fixture with measuring unit

- |                            |                             |
|----------------------------|-----------------------------|
| 1 Laser emission           | 6 Release / tightening knob |
| 2 Laser warning signal     | 7 Connection rod            |
| 3 Laser detector           | 8 Chain fixation screw      |
| 4 Vertical fine adjustment | 9 Locking chain             |
| 5 Spirit level             | 10 Mechanical fixture       |

## 2.1 Technical data

Denotation	1 mil = 1 thousandth of an inch
<b>Measuring units</b>	
Housing material	ABS plastic
Type of laser	Diode laser
Laser wave length	670 - 675 nm
Laser class	2
Maximum laser power	1 mW
Maximum distance between measuring units (measured between fixture center line)	850 mm (2.8 ft)
Minimum distance between measuring units (measured between fixture center line)	70 mm (2.7 in)
Type of detectors	Single-axis PSD, 8.5 x 0.9 mm (0.3 x 0.04 in)
Cable length	1.6 m (5.2 ft)
Dimensions	87 x 79 x 39 mm (3.4 x 3.1 x 1.5 in)
Weight	210 gram (7.3 oz)
<b>Display unit</b>	
Housing material	ABS plastic
Display type	LCD 35 x 48 mm (1.4 x 1.9 in)
Battery type	2 x 1.5V LR14 Alkaline
Operating time	20 hours continuous operating
Auto power off	after 1 hour if no keys are pressed
Displayed resolution	0.01 mm (0.1 mil with "inch" setting)
Dimensions	215 x 83 x 38 mm (8.4 x 3.2 x 1.4 in)
Weight	300 g (10.5 oz)
<b>Complete system</b>	
Shaft diameter range	30 - 150 mm (1.2 - 5.9 in)
Optional chain	150 - 500 mm (5.9 - 20 in)
Accuracy of system	<2% +/-0.01mm
Temperature range	0-40 °C (32 - 104 °F)
Operating humidity	< 90%
Carrying case dimensions	390 x 310 x 147 (15.3 x 12.2 x 5.7 in)
Total weight (incl. case)	3.6 kg (7.9 lb)
Calibration certificate	valid for two years
Warranty	12 months

### 3. Instructions for use

#### 3.1 Measurement units

##### Metric or imperial sizes

The tool is delivered with a pre-selection for measurements in millimeter. In case you want to change into inches, press the minus sign simultaneously to switching the tool on. To revert back to millimeter press the plus sign when switching on. The last setting will always be remembered.

#### 3.2 Feet on the ground

If there is any doubt whether the machine is resting equally on all feet please check for so called "soft foot". The procedure for this operation is described in chapter 3.10.

#### 3.3 Attachment of measuring units

- a) Use the fixtures to attach the measuring units to the shafts. Make sure that the M-marked unit is attached to the Movable machine and the S-marked unit to the Stationary machine. For diameters larger than 150 mm, an accessory extension chain (TMEA C2) is required.

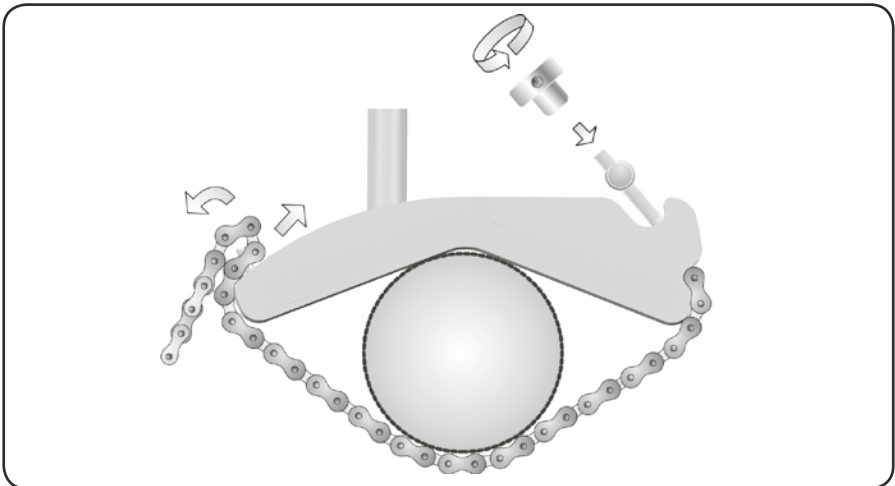

Fig. 8. Attachment of mechanical fixture with chain

If it is not possible to attach the fixtures directly to the shafts (e.g. in case of space problems) the fixtures can be attached to the coupling.

##### Note!

It is highly recommended to position the measuring units at equal distance from the middle of the coupling.

- b) Connect the measuring units to the display unit. Make sure that the marking on the cables corresponds to the marking of the ports in the display unit (fig. 9).

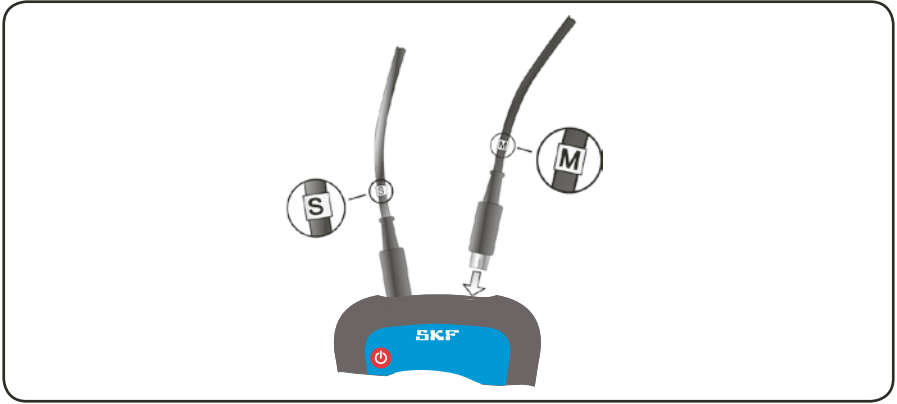

Fig. 9. Connection of the measuring units

### 3.4 Switch on

Switch on the display unit by pressing the ON/OFF button. You will now be prompted to enter the machine dimensions as per chapter 3.6. If no button is pressed within 60 minutes, the unit will turn off automatically.

### 3.5 Aiming the laser lines

- a) Put the two measuring units in the 12 o'clock position with the help of the spirit levels (fig. 10).

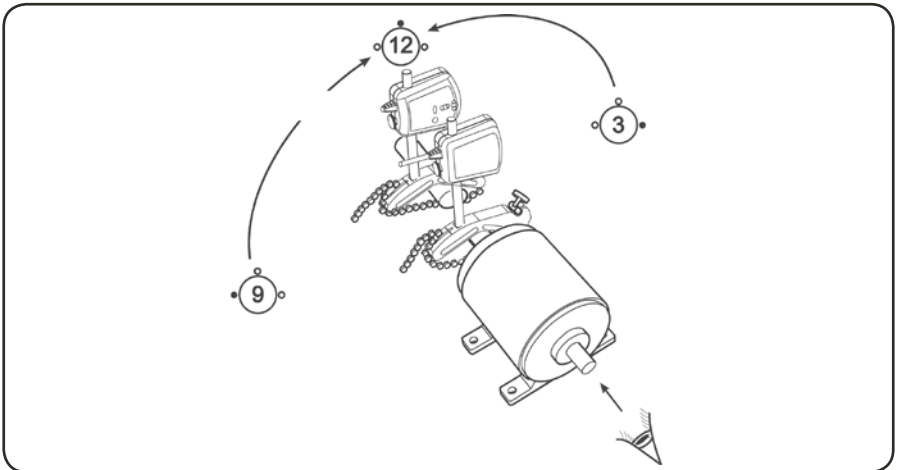

Fig. 10. The 12 o'clock position

- b) Aim the laser lines so that they hit in the centre of the target of the opposite measuring unit (fig. 11).

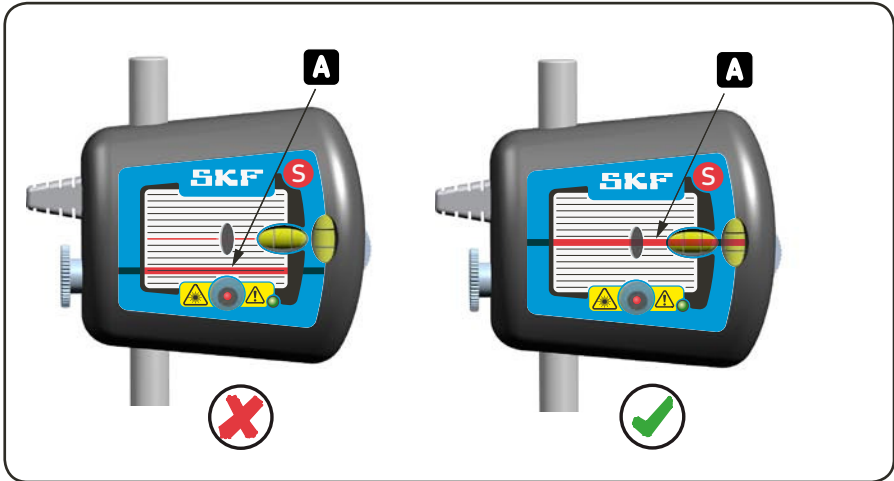

Fig. 11. Hit the target  
A Laser line

- c) For coarse adjustment release the measuring unit by unlocking the knob on the side of the unit (fig. 12). This allows the measuring unit to slide up and down the rod at the same time as it can swivel freely. For the fine adjustment in height use the adjustment wheels on the measuring units.

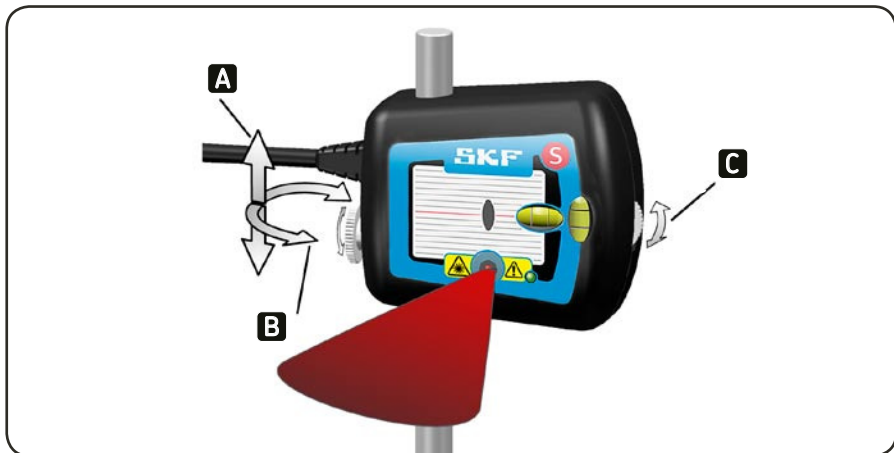

Fig. 12. Adjustment mechanism

- A Vertical positioning of measuring unit
- B Horizontal rotation of measuring unit
- C Vertical fine adjustment of laser

- d) If the horizontal alignment is very poor the laser lines might travel outside the detector areas. If this happens a rough alignment must be done. Do this by aiming the laser lines at the positioning detectors in the 9 o'clock position. Turn the measuring units to the 3 o'clock position when the lines will hit outside the detector areas. Adjust the lines to the position half-way between the detector centre and the actual position by means of the adjustment mechanism as per fig. 13. Align the Movable machine until the lines hit the centre of the positioning detector.

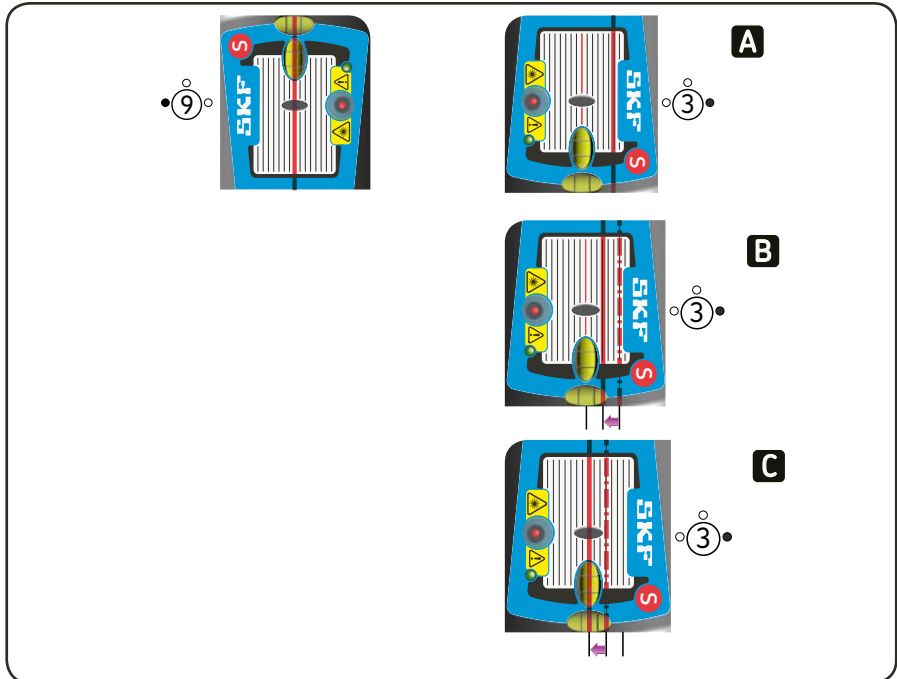

Fig. 13. Rough alignment

- A The beam moves outside the detector area
- B Adjust the beam to half the travel
- C Direct the machine to hit the centre

### 3.6 Machine dimensions

The configuration of the machinery is defined by three dimensions.

- A: The distance between the two measuring units, as measured between the fixture centre marks.
- B: The distance between the M-marked measuring unit and the front pair of feet of the Movable machine.
- C: The distance between the front feet and the rear feet of the Movable machine.

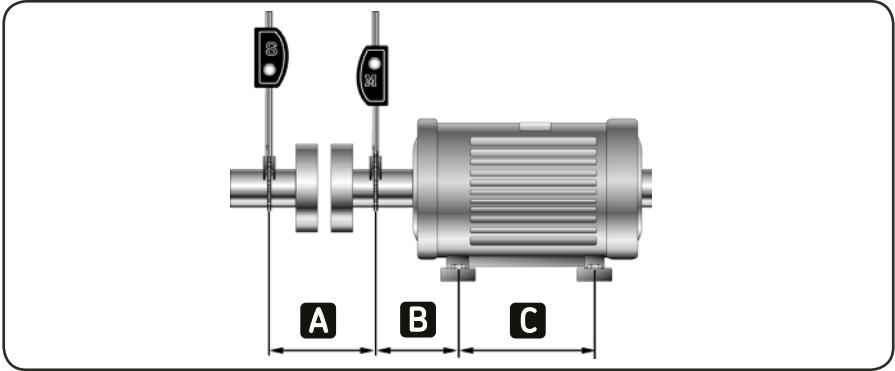

Fig. 14. Machine dimensions

- a) Measure the A, B and C distances. The default values for these three distances are:
  - A = 200 mm (8 in)
  - B = 200 mm (8 in)
  - C = 400 mm (15 in)
- b) Adjust each value by using the + and - buttons.
- c) Confirm the setting of each value by pressing the “next” button.

**Note!**

◀ If you need to go back and change values already entered use the “previous” button.

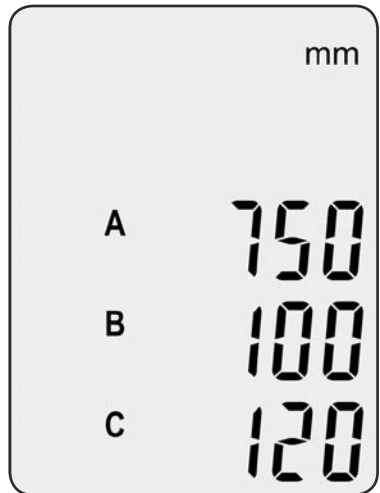

Fig. 15. Distances A, B and C

### 3.7 Measuring sequence

During the measuring cycle the shafts are rotated through 180 degrees. Any relative movement of the laser lines during this rotation indicates some sort of misalignment. The logic circuitry within the tool will translate this movement to misalignment figures and advise on how to correct it. A circle symbol on the display will help, indicating the required position of the measuring units during each step (fig. 16). As described earlier (chapter 1.3) we use the analogy of a clock to describe the different positions.



Fig. 16. Display guides you to the 9 o'clock position

- a) Adjust the measuring units to the 9 o'clock position with the aid of the spirit levels (fig. 17).
- b) Confirm the measurement by pressing

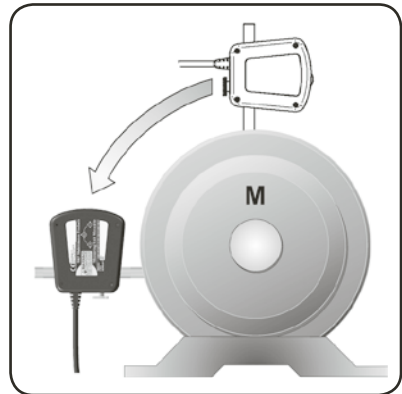



Fig. 17. Adjust to the 9 o'clock position

- c) Follow the circle symbol on the display and rotate the measuring units to the 3 o'clock position (fig. 18).
- d) Confirm the measurement by pressing



#### Note!

By pressing the “previous” button , you will reverse the process in order to repeat any of the measurement steps or to adjust any of the machine dimensions

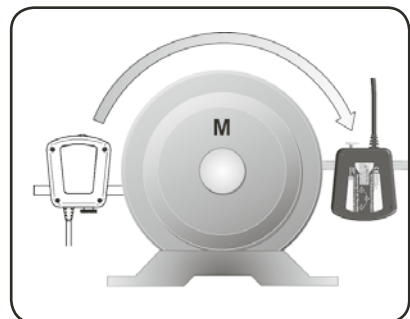



Fig. 18. Rotate to the 3 o'clock position

## 3.8 Alignment results

### 3.8.1 Measured misalignment

After the second measurement at 3 o'clock has been confirmed, the misalignment of the two machines in the measurement plane, the plane where the measuring units are (i.e. horizontal in this case) is displayed (fig. 19).

#### Coupling values

 The coupling value on top of the display shows the angle between the centre lines of the two shafts in the measurement plane (measured in mm/100 mm or 0.001"/1").

 The value below on the display shows the parallel off-set of the two centre lines in the measurement plane.

These two values are the coupling values in the measurement plane.

#### Feet values

The values F1 and F2 on the display indicate the relative positions of the Movable machine in the measurement plane.

**F 1** The F1 value indicates the relative position of the front pair of feet of the Movable machine.

**F 2** The F2 value indicates the relative position of the rear pair of feet of the Movable machine.

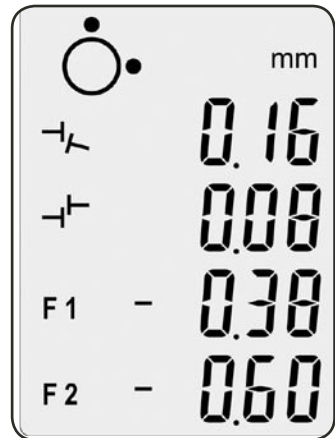

Fig. 19. Measured misalignment

### 3.8.2 Vertical alignment

Adjust the measuring units to the 12 o'clock position (fig. 20) with the aid of the spirit levels.

Observe the coupling and feet values live adjustment.

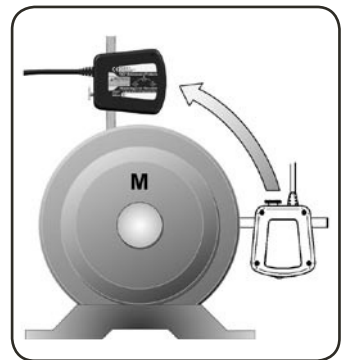





Fig. 20. The 12 o'clock position

The machine misalignment should always be within the manufacturer's specified tolerances. In case such tolerances are missing table 1 can be used as a rough guide-line.

Table 1. Acceptable maximum misalignment

				
rpm	mm/100 mm	mm	0.001"/1"	0.001"
0 - 1000	0.10	0.13	1.0	5.1
1000 - 2000	0.08	0.10	0.8	3.9
2000 - 3000	0.07	0.07	0.7	2.8
3000 - 4000	0.06	0.05	0.6	2.0
4000 - 6000	0.05	0.03	0.5	1.2

- a) If the measured coupling values are within the tolerances, the Movable machine does not have to be adjusted.  
Correct the horizontal misalignment. Continue to chapter 3.8.3 Horizontal alignment.
- b) If the measured coupling values are higher than the acceptable tolerances check the recommended corrections of the feet.

The F1 and F2 values on the display indicate the relative positions of the Movable machine when viewed from the side (fig. 21).



Fig. 21. Display vertical alignment

A positive value means that the feet are too high and need to be lowered while a negative value means the opposite (fig. 22).

Loosen the feet of the movable machine.

Use the shims included with the tool to adjust the height of the machine. Observe the coupling and feet values live adjustment and compare them with the values in table 1.

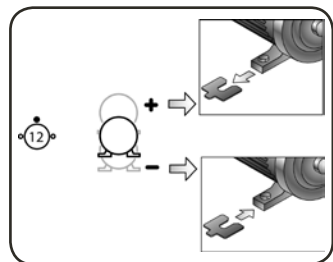

Fig. 22. Vertical alignment

After having carried out the vertical alignment proceed to the horizontal alignment (chapter 3.8.3).

### 3.8.3 Horizontal alignment

Move the measuring units to the 3 o'clock position (fig. 23).

Observe the coupling and feet values live adjustment.



Fig. 23. The 3 o'clock position

Machine misalignment should be within the manufacturer's specified tolerances. In case such tolerances are missing, table 1 can again be used as a general recommendation.

- a) If the measured coupling values are within the tolerances, no sideways adjustment is necessary.
- b) If the measured coupling values are higher than the acceptable tolerances check the recommended correction on the feet.

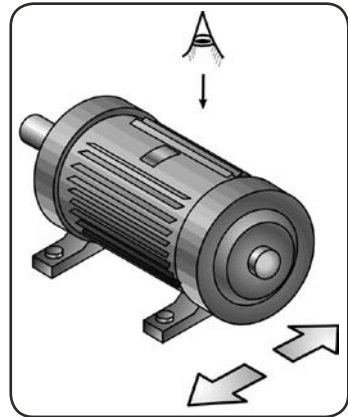

Fig. 24. Horizontal alignment

The F1 and F2 values indicated on the display give the relative positions of the Movable machine when viewed from above (fig. 25). The F1 value for the front pair of feet, the F2 value is for the rear pair of feet.

The alignment values indicate the necessary corrective sideways movement of the Movable machine (when viewed from behind the Movable machine). A negative value means that the feet have to be moved to the right. A positive value means that the feet have to be moved to the left (fig. 26).

Observe the coupling and feet values live adjustment while moving the movable machine sideways and compare them with the values in table 1.

The alignment is complete. Tighten the feet of the movable machine.



Fig. 25. Display horizontal alignment

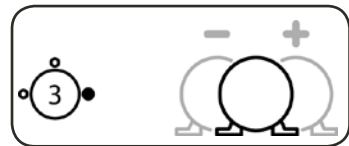

Fig. 26. Horizontal alignment

### 3.9 Verify alignment

To verify the alignment of the machinery, it is recommended to execute the measuring procedure once again. To do so, go back by using the previous button until you reach the first measuring step (9 o'clock position) and continue as per chapter 3.7.

### 3.10 Soft foot

Before starting the alignment it is recommended to check the Movable machine for soft foot. "Soft foot" is the expression used when a machine is not resting equally on all feet.

To find and correct the soft foot do as follows:

1. Tighten all bolts.
2. Execute all preparation steps as per chapter 3.1 to 3.6.

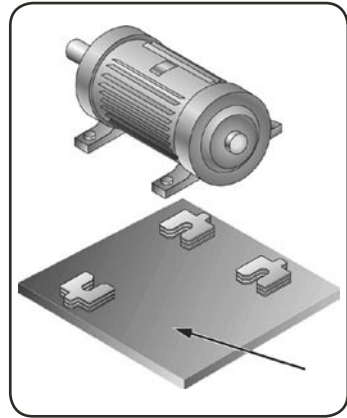

Fig. 27. Soft foot

A Soft foot

3. Press + and - simultaneously to reach the soft foot mode. The text "soft foot" should now be visible on the screen as shown on the figure 28.
4. Position the measuring units in the 12 o'clock position.
5. Press Next to zero the display values

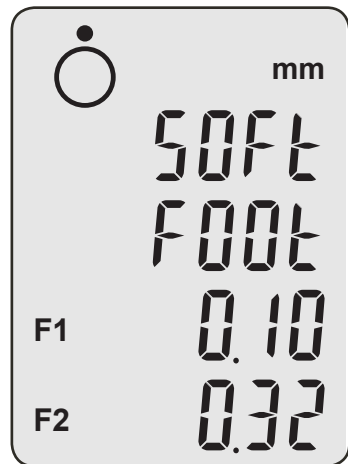

Fig. 28. Soft foot display

6. Loosen one of the bolts and monitor the change of the displayed values. Monitor the changes of the F1 value for a front foot, and of the F2 value for a rear foot.
  - If the deviations are less than 0.05 mm (2 mils), the foot has a good support. Tighten the bolt and go to the next foot.
  - If any of the deviations is larger than 0.05 mm (2 mils), the foot or its diagonally opposed foot is a soft foot. Tighten the bolt and check the diagonally opposed foot.
  - If the deviation is larger than the previously tightened foot, then this is the soft foot.
  - If not, tighten the bolt and go back to the previous diagonally opposed foot.It is normally worthwhile to try to improve the support of the soft foot by adding shims. Add the amount of shims corresponding to the larger deviation measured.

7. Tighten and loosen the bolt once again to check that the deviation does not exceed 0.05 mm (2 mils).
8. Repeat steps 5 to 8 for the remaining feet. The soft foot is now checked and corrected.
9. Press + and - simultaneously to leave the soft foot mode and enter the measuring sequence.

#### 4. Alignment report

A Shaft alignment report template is available on the CD ROM delivered with the unit. Or download the report from [www.mapro.skf.com](http://www.mapro.skf.com). The report contains the following data fields:

- a) Name of the equipment
- b) Name of the operator
- c) Date
- d) Name and/or reference of Stationary machine
- e) Name and/or reference of Movable machine
- f) Maximum rotational speed
- g) Maximum acceptable angle between centre lines of the shafts (see table 1, Ch. 3.8.2)
- h) Maximum acceptable off-set of centre lines (see table 1, Ch. 3.8.2)
- i) Selection of metric or imperial dimensions
- j) Machine configuration; distances A, B and C
- k) Soft foot correction done
- l) Vertical alignment: resulting angular error
- m) Vertical alignment: resulting parallel offset
- n) Horizontal alignment: resulting angular error
- o) Horizontal alignment: resulting parallel offset
- p) Vertical alignment: resulting height position of the front feet
- q) Vertical alignment: resulting height position of the rear feet
- r) Height of shims to be added or removed under front feet (excluding soft foot correction)
- s) Height of shims to be added or removed under rear feet (excluding soft foot correction)
- t) Horizontal alignment: resulting sideways position of the front feet
- u) Horizontal alignment: resulting sideways position of rear feet
- v) Remaining vertical angle
- w) Remaining vertical off-set
- x) Remaining horizontal angle
- y) Remaining horizontal off-set
- z) Space for own notes

Machinery equipment / position

a

Operator

b

Date

c

Stationary machine type

d

### Alignment report

Movable machine type

e

Rotational speed

f

rpm

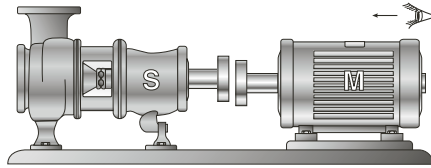

Acceptable coupling values

-1/2

-1/4

-1/8

-1/16

g

h

Measurement system

mm i / inch (\*/mils) i

Dimensions

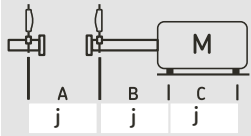

Machine configuration

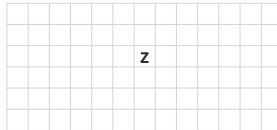

Soft foot correction

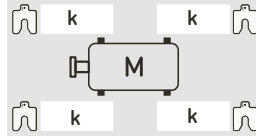

Measuring results height

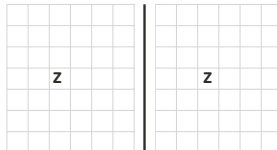
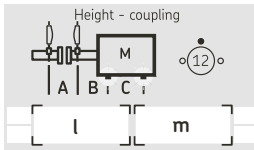

Measuring results sideways

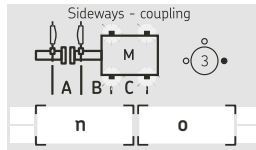

Height - feet position

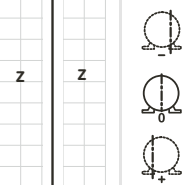
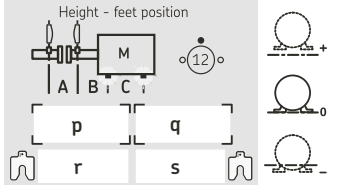

Sideways - feet position

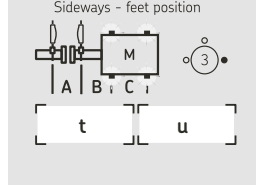

Remaining misalignment

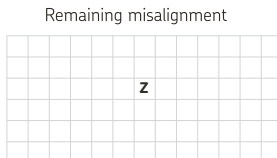
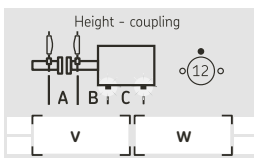

Sideways - coupling

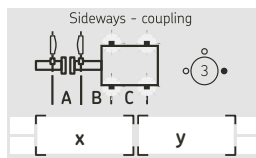

SKF Shaft alignment report



www.repair24.com • SKF is a registered trademark of the SKF Group • © SKF 2007 • M7536-1



## 5. Advanced use

### 5.1 Limited rotation

In some applications, limited space around the shaft coupling forbids the rotation of the measuring units to the 9 or 3 o'clock position. However, it is still possible to perform the alignment as long as the measuring units can rotate 180°.

Execute all preparation steps as per chapter 3.1 to 3.6.

Measuring sequence:

1. The display unit indicates that the measuring units should be placed in the 9 o'clock position. Since you can't reach it, place the measuring units in your start position (in our example 11 o'clock) and confirm the measurement by pressing the "next" button: .
2. The display unit now indicates the measuring units should be placed in the 3 o'clock position. Rotate the measuring units by 180° (in our example to the 5 o'clock position) and confirm the measurement: .
3. You can now complete the alignment following the instructions sequence as per chapter 3.8.

### 5.2 Trouble shooting

#### 5.2.1 The system does not switch on

- a) Check that batteries are inserted in the right way.
- b) Replace the batteries. Use principally Alkaline batteries for a better life span.

#### 5.2.2 No laser lines

- a) Make sure that the display unit is switched ON.
- b) Check the cables and connectors. Assure that all cables are properly connected.
- c) Check to see if the measuring units' warning LEDs flash.
- d) Replace the batteries.

#### 5.2.3 No measurement values

- a) Check the cables and connectors.
- b) Assure that the laser lines hit the positioning detectors.
- c) Assure uninterrupted travel of the laser lines.

#### 5.2.4 Fluctuating measurement values

- a) Assure tight attachment of fixtures and measuring units.
- b) Assure that the laser lines hit the detectors.
- c) Assure that air turbulence does not influence the measurement.
- d) Assure that direct bright light or obstructed laser lines do not influence the measurement results.

- e) Assure that external extensive vibrations do not influence the measurement.
- f) Assure that radio communications (like walkie-talkies) do not influence the measurement.

### **5.2.5 Incorrect measuring results**

- a) Assure you face the Stationary machine from behind the Movable machine.
- b) Check the attachment of fixtures and measuring units.
- c) S-cable to S-unit and M-cable to M-unit?
- d) S-unit on Stationary and M-unit on Movable machine?
- e) Assure right position before confirmation of measurements.

### **5.2.6 Measurement results cannot be repeated**

- a) Check if there is a soft foot condition.
- b) Check if there are any loose mechanical parts, play in bearing or movements in the machinery.
- c) Check the status of foundation, base plate, bolts and existing shims

## **6. Maintenance**

### **6.1 Handle with care**

The measuring units are equipped with sensitive electronic and optical parts. Handle them with care.

### **6.2 Cleanliness**

For best function the system should be kept clean. The optics near the laser and detector should be free of finger prints. If necessary clean with cotton cloth.

### **6.3 Batteries of the display unit**

The display unit is powered by two LR14 (C) batteries. Most LR14 (C) batteries can be used, but Alkaline batteries have the longest life. If not using the system for a long period, remove the batteries from the display unit. Flat batteries will be indicated by the battery signal on the display.

### **6.4 Replacement of measuring units or display unit**

Both measuring units are calibrated in pairs and hence they must be replaced as a pair.

## 6.5 Spare parts and accessories

---

<b>Designation</b>	<b>Description</b>
TKSA 20-DU	Display unit (TKSA 20 system)
TKSA-MU	Set of measuring units Movable and Stationary (TKSA and TMEA 2 system)
TMEA C1	Locking chains, set (500 mm) + tightening tool
TMEA C2	Extension chains set (1020 mm)
TMEA F2	1 chain fixture, complete
TMEA F7	Set with 3 pairs of connection rods (short: 150 mm, standard: 220 mm, long: 320 mm)
TMAS 340	Complete kit of 340 pre-cut machinery shims
TMAS 360	Complete kit of 360 pre-cut machinery shims
TMAS 510	Complete kit of 510 pre-cut machinery shims
TMAS 720	Complete kit of 720 pre-cut machinery shims

---

The contents of this publication are the copyright of the publisher and may not be reproduced (even extracts) unless prior written permission is granted. Every care has been taken to ensure the accuracy of the information contained in this publication but no liability can be accepted for any loss or damage whether direct, indirect or consequential arising out of use of the information contained herein.

## SKF Maintenance Products

© SKF is a registered trademark of the SKF Group.  
© SKF 2010/03

[www.mapro.skf.com](http://www.mapro.skf.com)  
[www.skf.com/mount](http://www.skf.com/mount)

MP5369E